

General Characteristics

Model Name	APD-ULJ250
Engine Make	John Deere
Engine Model	6090HF484
Alternator Make	Stamford
Control Panel Make & Model	DSE 7320
Frequency & Speed	60Hz, 1800rpm
Enclosure Make & Model	AKSA AUL 61/62



Genset Rating

Engine	Alternator	Voltage	Standby Power	Power Factor	Standby Current
6090HF484	HCI434D (Wnd-311)	480 / 277V	250kW	0.8	375A
	HCI434D (Wnd-311)	240 / 120V	250kW	0.8	752A
	HCI434D (Wnd-311)	208 / 120V	250kW	0.8	867A
	UCDI274J (Wnd-17)	600 / 347V	250kW	0.8	301A

*EPA – Certified for Emergency Stationary Applications

Stand-by Power (Maximum): Power available at variable load in the event of main power network failure. No over load is permitted.
 Prime Power: Power available at variable load in lieu of a main power network. Overload of 10% is permitted for 1 hour in every 12 hours of operation.
 The above ratings represent the engine performance capabilities to conditions specified in accordance with ISO 8528/5 & ISO3046.
Derating may be required for conditions outside of the test conditions.

Codes & Standards

The Generator set is designed and manufactured in a facility certified to **ISO9001** standards.

The Generator set is designed and manufactured in a facility certified to **ISO14001:2015** standards.

AKSA Power Generation provides **single source responsibility** for the generator set & accessories.

The generator set, with its components, are **prototype tested** and **production tested** according to the UL test program.

The generator set meets **NFPA70, 99, 110, 37** Level 1 when equipped with the necessary accessories and installed per NFPA standards.



*Manufacturer reserves the right to make changes in model, technical specifications, color, equipment and accessories without prior notice.

Engine Data

Manufacturer	John Deere
Model	6090HF484
Displacement & Cylinders	9 L / 6 Cylinders
Engine Type	In-line, 4 Cycle
Engine Speed	1800rpm
Engine Prime Power w/Fan	258kW
Engine Standby Power w/Fan	287kW
Aspiration	Turbocharged & Air to Air Aftercooled
Compression Ratio	16.0 : 1
Bore / Stroke	118.4 mm / 136 mm
Governor type	Electronic
Engine crankcase vent system	Open
Fan Power	17.2 kW
BMEP, Standby Power	2126 kPa
Friction Power	24kW
Designed / Calibrated to Meet	EPA Tier 3

Fuel System

ECU Description	L14 Controller
Max Fuel Inlet Temp.	176 °F
Total Fuel Flow	450 lb/hr

Fuel Consumption

Standby Power (100%)	18.0 gal/h
Standby Power (75%)	15.71 gal/h
Standby Power (50%)	11.14 gal/h

Electric System

System Voltage	12V / 24V
Min Voltage at ECU during crank	6V for 12V system 10V for 24V system
Battery Qty, Rating	2 x 120Ah

Cooling System

Radiator Cooling System Type	Closed Circuit
Radiator Ambient Temp	> 50 °C
Coolant Capacity, Engine Only	16.9 quart
Max Top Tank Temp	230 °F
Thermostat, Start – Fully Open	180– 201 °F

Exhaust System

Exhaust Temperature	1157°F
Max Allowable Exhaust Restriction	7.5 kPa
Exhaust Gas Flow	1911 ft ³ /min

Air Intake System

Engine Air Flow	812 ft ³ /min
Max Intake Air Restriction (Clean Element)	3.75 kPa
Air Filter Type	Dry Paper Element

Lubrication System

Oil Pressure at Rated Speed	260 kPa
Oil Pressure at low idle	190 kPa
Max Oil Carryover in Blow-by	0.007 lb/hr
Max Crankcase Pressure	0.5 kPa

Alternator Data

Manufacturer	Stamford
Standards	BS EN 60034
Control System	PMG
A.V.R.	MX341
Voltage Regulation	± 1 %
Insulation System	Class H
Protection	IP23
Rated Power Factor	0.8
Stator Winding	Double Layer Concentric
Winding Pitch	Two Thirds
Winding Leads	12
Telephone Interference	THF < 2 %
Waveform Distortion	No Load < 1.5 %
Maximum Over speed	2250 rev/min

Battery Charger & Electrical System Data

Manufacturer	ComAp
Model	InteliCharger
Input Voltage	85V ~ 264V AC
Output Voltage / Current	27.2V Float / 2.5A pk

Jacket Water Heater Data

Manufacturer	Hotstart
Model	TPS181GT10-000
Input Voltage	120V
Power	1800W

Controller Data

Manufacturer	DSE
Model	7320 MK II

Controller Features & Benefits

- Microprocessor controlled, UL & NFPA110 Compatible
- License free PC Software (Non-proprietary Software)
- IP65 rating offers increased resistance to water ingress
- Modules can be integrated to building management systems
- Real time clock provides accurate event log
- Four line back-lit LCD text display
- Five key menu navigation, two wire start/stop at Auto mode
- Front panel editing with PIN protection
- Support up to three remote display modules
- Configurable timers and alarms
- Multiple date and timer scheduler
- Integral PLC editor
- 'Protections disabled' feature
- Load switching (load shedding and dummy load outputs)
- Fully configurable via DSE Configuration Suite PC Software
- SCADA monitoring via DSE Configuration Suite PC Software

Protection

- ✓ Gen. Voltage – under / over
- ✓ Gen. Freq. – under / over
- ✓ Engine Speed – under / over
- ✓ Engine Oil Pressure –
- ✓ Engine Temp – low / high
- ✓ Battery Voltage – low / high
- ✓ Weak Battery
- ✓ Fail to Start / Stop
- ✓ Charge Alternator Fail
- ✓ Over Current & Load (kW/kVA_r)
- ✓ Unbalanced Load
- ✓ Independent Earth Fault
- ✓ Reverse Power
- ✓ Loss of Speed Signal

Instruments

- ✓ Gen. Voltage (L-L/L-N)
- ✓ Gen. Frequency
- ✓ Engine speed
- ✓ Oil Pressure
- ✓ Water Temperature
- ✓ Battery Voltage
- ✓ Run Time
- ✓ Phase Sequence
- ✓ Power monitoring (kWh/kVAh/kVA_rh)
- ✓ Power (kWh/kVAh/kVA_rh)
- ✓ Power Factor
- ✓ Generator Current
- ✓ Generator Load (%)
- ✓ Earth Current

Enclosure Features

- ✓ Heavy Duty Steel / Aluminum Structure
- ✓ E-Stop on Enclosure
- ✓ Control Panel Eliminated from Engine Vibrations
- ✓ Standard Sound Attenuation Foam
- ✓ Plastic Covered Corrosion Resistant Locks & Hinges

Enclosure Features

- ✓ Internally Mounted Exhaust System with Rain Cap
- ✓ Coolant Fill Cap
- ✓ Removable Base Frame Lifting Hooks
- ✓ Oil & Coolant Drain Ports
- ✓ Easy Access for Maintenance

Open Skid Gen		Level 1 Enclosure		Level 2 Enclosure	
Length	126 in	Length	161.7 in	Length	161.7 in
Width w/o lift hooks	55.1 in	Width w/o lift hooks	57.6 in	Width w/o lift hooks	57.6 in
Height	63.1 in	Height	79.8 in	Height	101.6 in
Dry Weight	5225 lb	Dry Weight	7200 lb	Dry Weight	8260 lb
		Sound Pressure @ 7 meters	78 dB(A)	Sound Pressure @ 7 meters	73 dB(A)

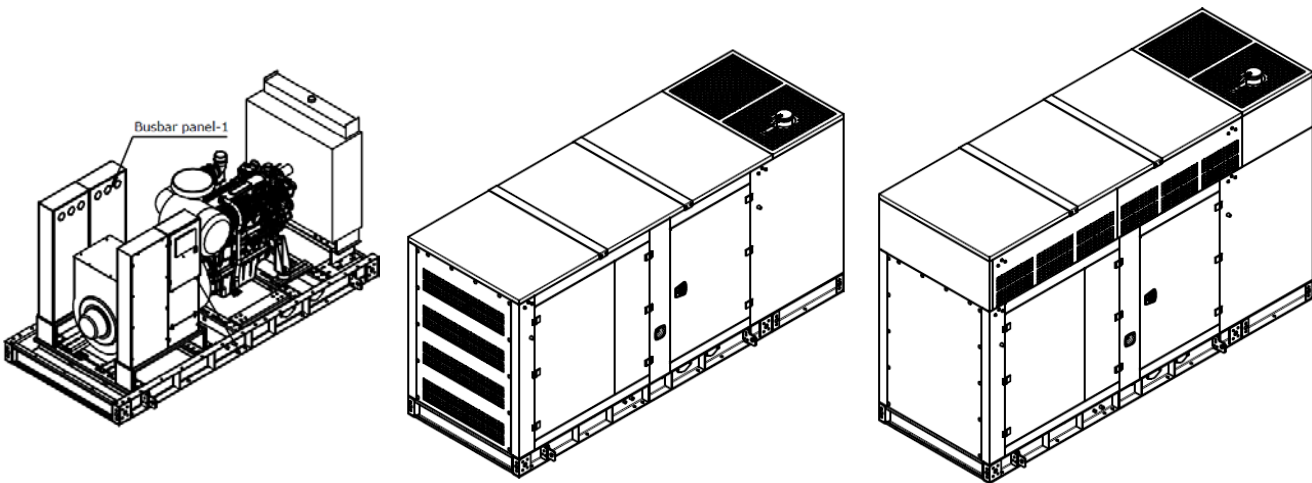

Fuel Tank - UL142 Listed Base Design

Size	24hr (425gal)	48hr (900gal)	72hr (1300gal)
Dimensions (L/W/H) (in)	182 / 55.1 / 16.5	182 / 55.1 / 32	222 / 55.1 / 36
Weight (lb)	2100	2800	3490

Standard Features & Accessories

- ✓ UL2200 Certification
- ✓ Heavy Duty Steel Base Frame
- ✓ PMG w/MX341 AVR
- ✓ Engine Jacket Water Heater
- ✓ Battery and Battery Rack
- ✓ Battery Charger
- ✓ Anti Vibration Pads between Engine/Alternator & Base Frame
- ✓ Critical Grade Silencer Inside Enclosure
- ✓ Residential Grade Silencer Set for Open Skid Sets
- ✓ Exhaust outlet rain cap and radiator fill cap
- ✓ Sound Absorb Foam Material for Enclosure
- ✓ Emergency Stop Button
- ✓ Oil Drain Valve
- ✓ Coolant Drain Valve
- ✓ Jacket Water Heater Isolation Valves
- ✓ Flex Fuel Lines
- ✓ Air Filter Restriction Gauge
- ✓ Engine Manifold Cover
- ✓ Turbocharger Cover
- ✓ Protection Covers for Rotating Parts
- ✓ Exhaust Insulation Cover
- ✓ Enclosure DC Light
- ✓ Operations Manual
- ✓ 24 Months / 2000 hours Limited Standby Warranty

Optional Accessories

- Main Line CB (3 / 4 Poles – 80% / 100% rated)
- Upsize Alternator
- Voltage Regulation $\pm 0.5\%$ w/MX321 AVR
- Anti-condensation Heater
- Sub Base Fuel Tank (UL142 / UL2085)
- Fuel Level Display & Alarm on Controller
- Low / High Fuel Alarms
- Fuel Water Separator Filter
- Auto Fuel Fill Control System
- Oil Temperature Display on Controller
- Manual Speed Adjust Rheostat
- Manual Voltage Adjust Rheostat
- Remote Annunciator Panel
- Remote Control & Monitoring Panel
- Advanced SMS Messaging
- Control Panel Heater
- Battery Disconnect Switch
- Battery Heater
- Battery Charger 10/20 Amp
- Shunt Trip / Aux Contacts
- Spring Anti-vibration Isolators
- Automatic Transfer Panel (ATS)
- 5 Years / 2000 hours Limited Comprehensive Warranty